

ALPHA – TEST SERIES



प्रा. चिराग सरांचे
Alpha 360° Academy



Academic Director
Prof. Chirag Senma



| Date | PHYSICS | CHEMISTRY | BIOLOGY |
|--------|---|---------------------|--------------|
| 19 May | <u>Mechanics</u> Mechanical Properties of Solids, Fluids | ORGANIC CHEMISTRY | 11th ZOOLOGY |
| 21 May | <u>Heat section</u> Oscillation & waves | INORGANIC CHEMISTRY | 12th ZOOLOGY |
| 24 May | Electric and Magnetic Section | PHYSICAL CHEMISTRY | 11th BOTANY |
| 26 May | Modern Physics Light & Waves | COMPLETE CHEMISTRY | 12th BOTANY |
| 30 May | Final Round Starts | | |

📍 Signal Camp, Udyog Bhavan, **Latur**

📞 **7767007744 | 7767007733**

🌐 www.alpha360degree.com

📍 Indraprastha Society, Opp. Netaji Subhash Mangal Karyalaya, Hadapsar, **Pune**

📞 **7378882123**



ALPHA 360 DEGREE ACADEMY

Date : 21-05-2026 Time : 3 Hrs

Physics : 45

Chemistry : 45

Biology : 90

Total : 180

Mark's-720

RE-NEET ALPHA TEST SERIES

TEST-02

Exam Syllabus

Physics : Heat Section + Oscillation & Waves

Chemistry : Inorganic Chemistry

Biology : 12th Zoology

Physics

01. The equation of a stationary wave is given as $y = A \sin 0.5 \pi t \cos (0.2 \pi x)$, where t is in seconds and x in centimetres. Which of the following is correct?

- 1) Wavelength of the component waves is 10 cm
- 2) The separation between a node and nearest antinode is 2.5 cm
- 3) Frequency at the component wave is 0.25 Hz
- 4) All of these

02. Two waves each of intensity i_0 and wavelength 0.2 m starts from sources A and B and meet at point P as shown in the figure. If $AP = 0.5$ m, $BP = 0.8$ m, then intensity at P is

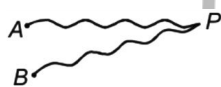

- 1) $2i_0$
- 2) i_0
- 3) $i_0/2$
- 4) zero

03. Given the equation for a wave on a string $y = 0.5 \sin(5x - 3t)$. When y and x are in meters and f in seconds. The ratio of maximum speed of particle to speed of wave is

- 1) 1 : 1
- 2) 5 : 2
- 3) 3 : 2
- 4) 4 : 5

04. If the tension in sonometer wire is increased by 69% keeping all other factors same, then the fundamental frequency of wire will

- 1) Increase by 30%
- 2) Decrease by 30%
- 3) Increase by 21%
- 4) Decrease by 21%

05. Find the acceleration of particle at $t = \frac{8}{3}$ s from the graph of wave motion

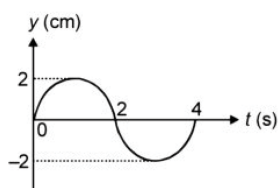

$$1) \frac{\sqrt{3}\pi^2}{4} \quad 2) -\frac{\sqrt{3}\pi^2}{4}$$

$$3) -\pi^2 \quad 4) \text{zero}$$

06. The ratio of amplitudes of two coherent waves are 5 : 3 then the ratio of maximum to minimum intensities in their interference pattern are

- 1) 1 : 16
- 2) 16 : 1
- 3) 5 : 3
- 4) 25 : 9

07. Equation of a stationary wave is $y = 0.6 \sin(314t) \cos(3.14x)$, where x is in metre and t is in second. Distance between two consecutive nodes is

- 1) 2 m
- 2) 1.5 m
- 3) 1 m
- 4) 0.5 m

08. An open and a closed pipe have same length, the ratio of frequency of their 3rd overtone is

$$1) \frac{8}{7} \quad 2) \frac{4}{7}$$

$$3) \frac{3}{7} \quad 4) \frac{2}{7}$$

09. A uniform rope of length l is suspended from a ceiling as shown. A particle is dropped from the ceiling at the instant a wave pulse is formed at the lower end. Where will the particle meet the pulse?

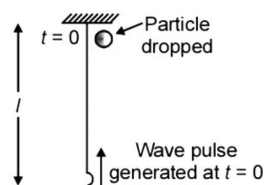

$$1) \frac{l}{3} \text{ distance form the top}$$

$$2) \frac{l}{3} \text{ distance from the bottom}$$

$$3) \frac{l}{4} \text{ distance from the bottom}$$

$$4) \text{At mid point of the rope}$$

10. The equation of an SHM is given as $x = 5 \sin\left(4\pi t + \frac{\pi}{3}\right)$, where t is in seconds and x in metres. During a complete cycle the average speed of the oscillator is
- zero
 - 10 m/s
 - 20 m/s
 - 40 m/s
11. The amplitude of oscillation for a particle executing S.H.M with angular frequency π rad/s and maximum acceleration $5\pi^2$ m/s² is
- 25 cm
 - 25 m
 - 5 cm
 - 5 m
12. Find the % change in time period if the length of simple pendulum is increased by 3%
- 3%
 - 6%
 - 1.5%
 - 2.5%
13. The time period of a body under S.H.M. is T_1 and T_2 when restoring forces F_1 and F_2 respectively act on it. What will be the time period of S.H.M. when both the forces act simultaneously on it ?
- $\frac{T_1 T_2}{T_1 + T_2}$
 - $T_1 + T_2$
 - $\sqrt{\frac{T_1^2 + T_2^2}{T_1 T_2}}$
 - $\frac{T_1 T_2}{\sqrt{T_1^2 + T_2^2}}$
14. A particle executes SHM of amplitude 10 m and period 4 s along straight line. The velocity of the particle at a distance 6 m from mean position is
- 2π m/s
 - 4π m/s
 - 6π m/s
 - 5.47π m/s
15. The potential energy of a particle executing SHM is 2.5 J, when its displacement is half of amplitude. The total energy of particle is
- 18 J
 - 10 J
 - 12 J
 - 2.5 J
16. Choose the incorrect statement
- All SHM's have fixed time period.
 - All motions having same time period are SHM.
 - In SHM, total energy is proportional to square of amplitude
 - Phase constant of SHM depends upon initial conditions
17. In the spring pendulum, in the place of mass liquid is used. If liquid leaks out continuously then time period of spring pendulum
- Decreases continuously
 - Increases continuously
 - First increased and then decreased
 - First decreased then increased

18. A particle is moving along the x-axis. The speed of particle v varies with position x as $\frac{v^2}{144} + \frac{x^2}{9} = 1$. The time period of S.H.M. is
- π unit
 - $\frac{3\pi}{2}$ unit
 - $\frac{\pi}{2}$ unit
 - $\frac{\pi}{4}$ unit
19. Tension in a stretched wire is increased by 56.25%. In order to keep frequency unchanged, length of the wire is to be increased by
- 15%
 - 25%
 - 30%
 - 40%
20. A travelling wave pulse is given by $y = \frac{20}{4 + (x + 4t)^2}$ (m), then
- The pulse is travelling along negative x axis
 - The speed of pulse is 4 m/s
 - The amplitude of pulse is 5 m
 - All of these
21. The equation of two waves are given by $y_1 = 0.2m \sin(200\pi t + \pi)$
 $y_2 = 0.1m \sin(200\pi t - \frac{\pi}{2})$
- If they are superimpose at a point, then the maximum amplitude is
- $\sqrt{0.05}m$
 - $\sqrt{0.03}m$
 - $\sqrt{0.09}m$
 - $\sqrt{0.07}m$
22. The graph of Fahrenheit temperature (F) versus Celsius temperature (C) is shown below. The correct relation between F and C which can be deduced from graph, is

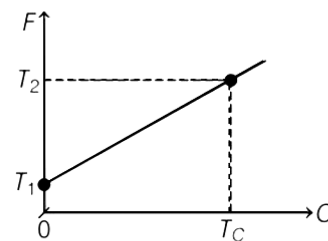

- $\frac{F - 32}{T_2 - T_1} = \frac{T_c}{C}$
- $\frac{F - T_1}{T_2 - T_1} = \frac{C}{T_c}$
- $\frac{F - 32}{T_2 - T_1} = \frac{C}{T_c}$
- $\frac{C}{T_2 - T_1} = \frac{F - 32}{T_c}$

34. Choose the correct statement regarding isobaric process
- 1) $pV = \text{constant}$
 - 2) Heat absorbed by the gas goes partly to increase internal energy and partly to do work
 - 3) The system returns to its initial state
 - 4) Both '1' and '2'
35. Consider p-V diagram for an ideal gas shown in figure.

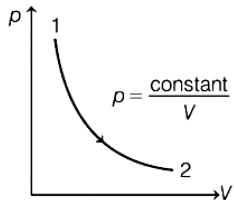

Out of the following diagrams, which figure represents the T-p diagram ?

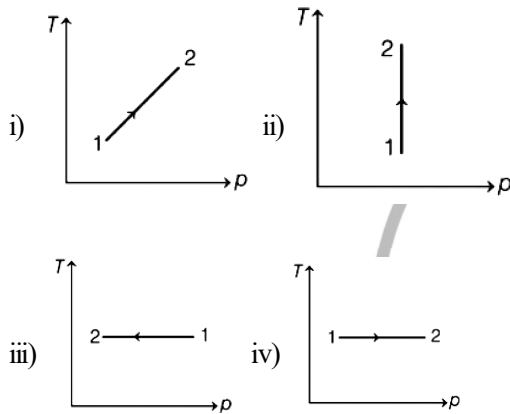

- 1) (iv)
 - 2) (ii)
 - 3) (iii)
 - 4) (i)
36. A gas is filled in a vessel. Its temperature is increased by 25% on Kelvin scale and volume is decreased by 10%. How much percentage of the gas has to leak for pressure to remain constant ?
- 1) 25 %
 - 2) 20 %
 - 3) 28 %
 - 4) 30 %
37. When the temperature of a gas increases by 1°C at constant volume, its pressure increases by 0.4 %. What is its initial temperature ?
- 1) 250°C
 - 2) 125°C
 - 3) 195°C
 - 4) 329°C
38. Oxygen and hydrogen are at the same temperature T. The ratio of the mean kinetic energy of oxygen molecules to that of the hydrogen molecules will be
- 1) 16 : 1
 - 2) 1 : 1
 - 3) 4 : 1
 - 4) 1 : 4
39. An ideal gas ($\gamma = 1.5$) is expanded adiabatically. How many times the gas has to be expanded to reduce the root mean square velocity of the molecules 2.0 times?

- 1) 4 times
 - 2) 16 times
 - 3) 8 times
 - 4) 2 times
40. For a given gas at 1 atm. pressure, rms speed of the molecules is 200 m/s at 127°C . At 2 atm pressure and at 227°C , the rms speed of the molecules will be
- 1) $100\sqrt{5}$ m/s
 - 2) 80 m/s
 - 3) 100 m/s
 - 4) $80\sqrt{5}$ m/s
41. If γ is the ratio of specific heats and R is the universal gas constant, then the molar specific heat at constant volume C_v is given by
- 1) γR
 - 2) $\frac{(\gamma - 1)R}{\gamma}$
 - 3) $\frac{R}{\gamma - 1}$
 - 4) $\frac{\gamma R}{\gamma - 1}$
42. The temperature of an ideal gas increases to 2 times when compressed adiabatically to half the volume. Its equation of state can be written as
- 1) $pV^{3/2} = \text{constant}$
 - 2) $pV^{4/3} = \text{constant}$
 - 3) $pV^{1/2} = \text{constant}$
 - 4) $pV^2 = \text{constant}$
43. 10 mol of an ideal gas at constant temperature 500 K is compressed from 50L to 5L. Work done in the process is (given, $R = 8.31 \text{ J mol}^{-1}\text{K}^{-1}$)
- 1) $-1.2 \times 10^4 \text{ J}$
 - 2) $-2.4 \times 10^4 \text{ J}$
 - 3) $-4.8 \times 10^4 \text{ J}$
 - 4) $-9.6 \times 10^4 \text{ J}$
44. The two ends of a metal rod are maintained at temperature 100°C and 110°C . The rate of heat flow in the rod is found to be 4 Js^{-1} . If the ends are maintained at temperature 200°C and 210°C , the rate of heat flow will be
- 1) 44.0 Js^{-1}
 - 2) 16.8 Js^{-1}
 - 3) 8.0 Js^{-1}
 - 4) 4.0 Js^{-1}
45. A bimetallic strip consists of metals X and Y. It is mounted rigidly at the base as shown in figure. The metal X has a higher coefficient of expansion compared to that of metal Y. When bimetallic strip is placed in a cold bath, then

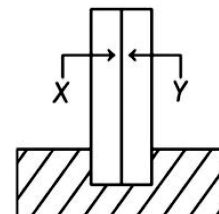

- 1) it will bend towards the right
- 2) it will bend towards the left
- 3) it will not bend but shrink
- 4) it will neither bend nor shrink

71. C-O bond length is longest in
 1) $[\text{Mn}(\text{CO})_6]^+$ 2) $[\text{V}(\text{CO})_6]^-$
 3) $[\text{Cr}(\text{CO})_6]$ 4) $[\text{Ti}(\text{CO})_6]^{2-}$
72. Hardness of water is estimated by its titration with
 1) CaEDTA 2) Mg EDTA
 3) Na_2 EDTA 4) BaEDTA
73. A salt gives white residue in charcoal cavity test but in cobalt nitrate test it gives pink mass. It represents:
 1) Zn^{+2} 2) Al^{+3}
 3) Mg^{+2} 4) PO_4^{-3}
74. Which of the following combines with Fe(II) ions to form a brown complex?
 1) N_2O 2) NO
 3) N_2O_3 4) N_2O_4
75. Which of the following compound does not give ppt with dil. HCl?
 1) AgNO_3 2) $\text{Pb}(\text{NO}_3)_2$
 3) $\text{Hg}_2(\text{NO}_3)_2$ 4) $\text{Hg}(\text{NO}_3)_2$
76. Which of the following represents the correct order of EA?
 1) $\text{O} > \text{C} > \text{N} > \text{Br} > \text{Cl} > \text{F}$
 2) $\text{Cl} > \text{F} > \text{O} > \text{C} > \text{N} > \text{Be}$
 3) $\text{Cl} > \text{O} > \text{F} > \text{C} > \text{N} > \text{Be}$
 4) $\text{O} > \text{C} > \text{Cl} > \text{N} > \text{Be} > \text{F}$
77. Statement I: Helium is an inert gas.
 Statement II: Valence shell of helium is completely filled.
 1) Both Statement I and Statement II are true.
 2) Both Statement I and Statement II are false.
 3) Statement I is true but Statement II is false.
 4) Statement I is false but Statement II is true
78. Molecular shapes of SF_4 , CF_4 and XeF_4 are
 1) The same with 2, 0 and 1 lone pair of electrons
 2) The same with 1, 1 and 1 lone pair of electrons
 3) Different with 0, 1 and 2 lone pair of electrons
 4) Different with 1, 0 and 2 lone pair of electrons
79. The correct order of bond angle is
 1) $\text{H}_2\text{S} < \text{NF}_3 < \text{BF}_3 < \text{CH}_4$
 2) $\text{NH}_3 < \text{H}_2\text{S} < \text{CH}_4 < \text{BF}_3$
 3) $\text{H}_2\text{S} < \text{NH}_3 < \text{CH}_4 < \text{BF}_3$
 4) $\text{H}_2\text{S} < \text{CH}_4 < \text{NH}_3 < \text{BF}_3$
80. In O_2^- , O_2 and O_2^{2-} molecular species, the total number of bonding electrons, respectively, are
 1) 7,6,8 2) 11, 10, 12
 3) 10,10,10 4) 8, 6, 8
81. **Column-I** **Column-II**
 (a) Carbon (i) Component of glass
 (b) Silicon (ii) Most versatile element
 (c) Germanium (iii) Mainly occurs as cassiterite
 (d) Tin (iv) Used in production of Semiconductors
- 1) a-ii, b-iii, c-iv, d-i
 2) a-ii, b-i, c-iv, d-iii
 3) a-i, b-ii, c-iii, d-iv
 4) a-iv b-iii, c-ii, d-i
82. The element with highest melting point among Group 15 elements is
 1) nitrogen 2) arsenic
 3) bismuth 4) selenium
83. Addition of electron is most endothermic for
 1) He 2) Ne
 3) Ar 4) Xe
84. The maximum oxidation state shown by V (Z = 23), Cr (Z = 24), Co (Z = 27), Sc (Z = 21) are, respectively,
 1) +5,+6,+4,+3 2) +3,+4,+5,+2
 3) +5,+3,+2,+1 4) +4 in each case.
85. Composition of alloy mischmetal is
 1) Lanthanoid metal and fluorine
 2) Lanthanoid metal and iron
 3) Lanthanoid metal and sulphur
 4) Lanthanoid metal and silver
86. **Column -I** **Column - II**
 (i) Th (a) $[\text{Rn}] 5f^{14} 6d^1 7s^2$
 (ii) Pu (b) $[\text{Rn}] 5f^7 6d^1 7s^2$
 (iii) Cm (c) $[\text{Rn}] 6d^2 7s^2$
 (iv) Lr (d) $[\text{Rn}] 5f^6 7s^2$
- 1) (i)-(c), (ii) (d), (iii)-(b), (iv)-(a)
 2) (i)-(a), (ii)-(c), (iii)-(b), (iv)-(d)
 3) (i)-(b), (ii) (a), (iii)-(d), (iv)-(c)
 4) (i)-(d), (ii)-(b), (iii)-(a), (iv)-(c)

87. A metal present in vitamin B₁₂ is

- 1) aluminium 2) cobalt
3) iron 4) zinc.

88. Choose the heteroleptic complexes

- (a) $[\text{Co}(\text{NH}_3)_6]^{3+}$ (b) $[\text{Fe}(\text{H}_2\text{O})_4\text{Cl}_2]^+$
(c) $\text{Fe}(\text{CO})_5$ (d) $[\text{Co}(\text{NH}_3)_4\text{Cl}_2]^+$
1) (a) and (c) only 2) (a) and (d) only
3) (b) and (d) only 4) (b) and (c) only

...ALPHA 360 Degree Acad-

89. Which of the following complex is an outer orbital complex?

- 1) $[\text{Ni}(\text{NH}_3)_6]^{2+}$ 2) $[\text{Mn}(\text{CN})_6]^{4-}$
3) $[\text{Co}(\text{NH}_3)_6]^{3+}$ 4) $[\text{Fe}(\text{CN})_6]^{4-}$

90. H₂S in the presence of HCl precipitates II group but not IV group because :

- 1) HCl activates H₂S
2) HCl increases concentration of Cl⁻
3) HCl decreases concentration of S²⁻
4) HCl lowers the solubility of H₂S in solution

Space For Rough Work



113. Which of the following produce an army of proteins called antibodies in response to pathogens into our blood to fight with them ?

- 1) B-lymphocytes
- 2) T-lymphocytes
- 3) Polymorpho-nuclear leucocytes
- 4) Neutrophils

114. Which of the following statements are correct regarding female reproductive cycle ?

- A. In non-primate mammals cyclical changes during reproduction are called oestrus cycle.
- B. First menstrual cycle begins at puberty and is called menopause.
- C. Lack of menstruation may be indicative of pregnancy.
- D. Cyclic menstruation extends between menarche and menopause.

Choose the most appropriate answer from the options given below :

- 1) A and B only
- 2) A, B and C only
- 3) A, C and D only
- 4) A and D only

115. Given below are two statements regarding oogenesis:

Statement I :- The primary follicles get surrounded by more layers of granulosa cells, a theca and shows fluid filled cavity antrum. Now it is called secondary follicle.

Statement II :- Graffian follicle ruptures to release the secondary oocyte from the ovary by the process called ovulation.

In the light of the above statements, choose the correct answer from the options given below:

- 1) Statement I is correct but Statement II is false.
- 2) Statement I is incorrect but Statement II is true
- 3) Both Statement I and Statement II are true
- 4) Both Statement I and Statement II are false.

116. Identify the correct statement with reference to immunity.

- 1) When exposed to pre-formed antibodies some anti-bodies are produced in the host's body. It is called 'active immunity'.
- 2) When ready-made antibodies are directly given, it is called 'active immunity'.
- 3) Active immunity is quick and gives full response.
- 4) Fetus receives some antibodies from the mother. It is an example of passive immunity.

117. Element required to maintain structure of immunoglobulin is

- 1) S
- 2) Ca
- 3) P
- 4) Fe

118. Recognise the figure and find out the correct matching.

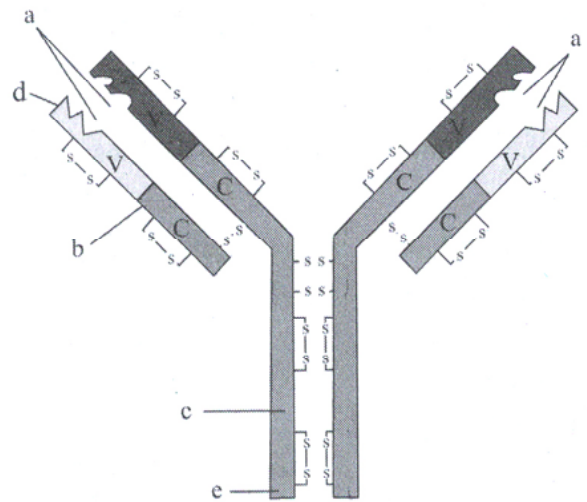

- 1) b—Light chain, c—Heavy chain, d—N terminal, e—C terminal, a—Antigen binding site
- 2) b—Light chain, c—Heavy chain, e—N terminal, d—C terminal, a—Antigen binding site
- 3) c—Light chain, b—Heavy chain, d—N terminal, e—C terminal, a—Antigen binding site
- 4) c—Light chain, b—Heavy chain, a—N terminal, d—C terminal, e—Antigen binding site

119. During Implantation, the blastocyst gets embedded in which layer of the uterus?

- 1) Trophoblast
- 2) Endometrium
- 3) Myometrium
- 4) Perimetrium

120. Match the following columns and choose the correct option.

| | Column I | | Column II |
|---|-------------------------------|---|---|
| 1 | <i>Epidermophyton</i> | a | Blockage of the intestinal passage |
| 2 | <i>Wuchereria bancrofti</i> | b | Intense itching |
| 3 | <i>Ascaris</i> | c | Stools with excess mucous and blood clots |
| 4 | <i>Entamoeba histolytica</i> | d | Severe problem in respiration |
| 5 | <i>Haemophilus influenzae</i> | e | Chronic inflammation of the organs |

- 1) 1 - b, 2 - e, 3 - c, 4 - a, 5 - d
- 2) 1 - e, 2 - b, 3 - a, 4 - c, 5 - d
- 3) 1 - b, 2 - a, 3 - e, 4 - d, 5 - c
- 4) 1 - b, 2 - e, 3 - a, 4 - c, 5 - d

121. Which one of the following is not the function of placenta ? It :-
 1) secretes oxytocin during parturition
 2) facilitates supply of oxygen and nutrients to embryo
 3) secretes estrogen
 4) facilitates removal of carbon dioxide and waste material from embryo
122. In human adult females oxytocin :-
 1) Stimulates pituitary to secrete vasopressin
 2) Causes strong uterine contractions during parturition
 3) is secreted by anterior pituitary
 4) stimulates growth of mammary glands
123. Many fungi are responsible for ringworm which belong to genera
 1) *Trichophyton* and *Epidermophyton*
 2) *Microsporum* and *Trichophyton*
 3) *Epidermophyton* and *Trichophyton*
 4) All of the above
124. Which of the following statements is not correct ?
 1) In the absence of fertilization, the corpus luteum is degenerated.
 2) During pregnancy, all events of menstrual cycle are stopped.
 3) The secretion of LH and FSH decreases gradually during the follicular phase.
 4) The menstrual flow results due to breakdown of endometrial lining.
125. The infectious agents are transmitted through food and water in
 1) Typhoid 2) Amoebiasis
 3) Ascariasis 4) All of the above
126. Arrange the components of mammary gland. (from proximal to distal)
 (a) Mammary duct
 (b) Lactiferous duct
 (c) Alveoli
 (d) Mammary ampulla
 (e) Mammary tubules
 Choose the most appropriate answer from the options given below :
 1) (c) → (a) → (d) → (e) → (b)
 2) (b) → (c) → (e) → (d) → (a)
 3) (c) → (e) → (a) → (d) → (b)
 4) (e) → (c) → (d) → (b) → (a)
127. In malaria, which of the following is responsible for the chill and high fever recurring every three to four days ?
 1) Haemozoin 2) Cryptozoites
 3) Sporozoites 4) Trophozoites
128. The function of fimbriae is :-
 1) to collect ovum after ovulation
 2) to maintain the shape of ovary
 3) to provide the path to sperm during fertilization
 4) None of the above
129. When do both LH & FSH attain a peak level in a menstrual cycle ?
 1) In last week of the cycle
 2) In mid of the cycle
 3) During Initial days of cycle
 4) On 4th day of cycle
130. *Salmonella typhi* generally enters in the
 1) Liver 2) Small intestine
 3) Lungs 4) Spleen
131. Flippers of penguins and dolphins are examples of
 1) Convergent evolution
 2) Industrial melanism
 3) Natural selection
 4) Adaptive radiation
132. **Assertion (A)** : During pregnancy the level of thyroxine is increased in the maternal blood.
Reason (R) : Pregnancy is characterised by metabolic changes in the mother.
 1) Both (A) and (R) are correct and (R) is the correct explanation of (A)
 2) Both (A) and (R) are correct but (R) is not the correct explanation of (A)
 3) (A) is correct but (R) is not correct
 4) (A) is not correct but (R) is correct
133. Which of the following statements is correct about the origin and evolution of men ?
 1) Agriculture came around 50,000 years back
 2) The *Dryopithecus* and *Ramphithecus* primates existing 15 million years ago, walked like men
 3) *Homo habilis* probably ate meat
 4) Neanderthal men lived in Asia between 1,00,000 and 40,000 years back.
134. From his experiments, S.L. Miller produced amino acids by mixing the following in a closed flask
 1) CH₃, H₂, NH₄ and water vapour at 800°C
 2) CH₄, H₂, NH₃ and water vapour at 600°C
 3) CH₃, H₂, NH₃ and water vapour at 600°C
 4) CH₄, H₂, NH₃ and water vapour at 800°C
135. The blastomeres in the blastocyst are arranged into an outer layer called ___A___, and inner group of cells attached to trophoblast called the ___B___. What are 'A' and 'B' respectively ?
 1) trophoblast, inner cell mass
 2) inner cell mass, trophoblast
 3) chorion, amnion
 4) amnion, chorion

136. Spermeiogenesis is the process of transformation of

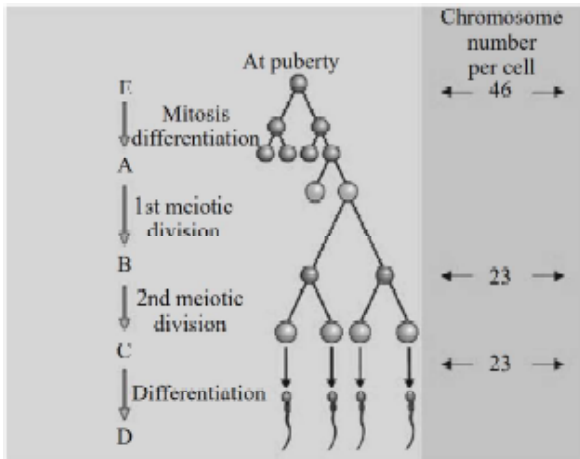

- 1) A to B 2) B to C
3) C to D 4) E to A

137. In Australia, marsupials and placental mammals have evolved to share many similar characteristics. The type of evolution may be referred to as

- 1) Adaptive radiation
2) Divergent evolution
3) Cyclical evolution
4) Convergent evolution

138. Which among these is the correct combination of aquatic mammals ?

- 1) Dolphins, Seals, Trygon
2) Whales, Dolphins, Seals
3) Trygon, Whales, Seals
4) Seals, Dolphins, Sharks

139. The chronological order of human evolution from early to the recent is

- 1) *Ramapithecus* → *Homo habilis*
→ *Australopithecus* → *Homo erectus*
2) *Australopithecus* → *Homo habilis*
→ *Ramapithecus* → *Homo erectus*
3) *Australopithecus* → *Ramapithecus* →
Homo habilis → *Homo erectus*
4) *Ramapithecus* → *Australopithecus* →
Homo habilis → *Homo erectus*

140. Which one of the following is the correct matching of the events occurring during menstrual cycle ?

- 1) Menstruation : Breakdown of myometrium and ovum not fertilised
2) Ovulation : LH and FSH attain peak level and sharp fall in the secretion of progesterone.
3) Proliferative : Rapid regeneration of phase myometrium and maturation of Graafian follicle.
4) Development of : Secretory phase and corpus luteum increased secretion of progesterone.

141. Analogous structures are a result of

- 1) Shared ancestry
2) Stabilizing selection
3) Divergent evolution
4) Convergent evolution

142. At the time of ovulation, the human egg is covered by a membrane called as :-

- 1) chorion 2) zona pellucida
3) corona radiata 4) Both (2) & (3)

143. The eye of Octopus and eye of cat show different patterns of structure, yet they perform similar function. This is an example of

- 1) Analogous organs that have evolved due to convergent evolution
2) Analogous organs that have evolved due to divergent evolution
3) Homologous organs that have evolved due to convergent evolution
4) Homologous organs that have evolved due to divergent evolution

144. Correct sequence of embryonic development is :-

- 1) Fertilization → Zygote → Cleavage → Morula → Blastula → Gastrula
2) Fertilization → Zygote → Blastula → Morula → Cleavage → Gastrula
3) Fertilization → Cleavage → Morula → Zygote → Blastula → Gastrula
4) Cleavage → Zygote → Fertilization → Morula → Blastula → Gastrula

145. Which ones are not analogous organs ?

- 1) Wings of birds and wings of butterfly
2) Eye of Octopus and eye of mammals
3) Flippers of penguins and flippers of Dolphin
4) Thorns of *Bougainvillea* and tendrils of *Cucurbita*

146. Sertoli cells are involved in :-

- 1) respiration
2) nutrition of sperms
3) excretion
4) development of sex organs

147. Amniocentesis is:-

- 1) Analysis of chemical composition of fluids of pregnant woman
2) Withdrawal of allantoic fluid from pregnant women
3) An in vitro diagnosis
4) Culturing of cells and study of metaphase chromosomes from amniotic fluid to identify chromosomal abnormality

148. Which of the following hormones are produced in women only during pregnancy ?

- (a) hPL (b) Relaxin
 (c) Androgen (d) FSH
 (e) hCG (f) LH
 1) a, b, e 2) b & e
 3) c, d, e, f 4) a, b, c, d, e, f

149. In human foetus, the heart begins to beat at developmental age of :-

- 1) 4 weeks 2) 3 weeks
 3) 6 weeks 4) 8 weeks

150. **Assertion :** Theory of chemical evolution proposed that life come from pre-existing non-living organic molecules.

Reason : The primitive earth conditions led to production of organic molecules.

- 1) If both assertion and reason are true and the reason is the correct explanation of the assertion.
 2) If both assertion and reason are true but reason is not the correct explanation of the assertion.
 3) If assertion is true but reason is false.
 4) If both assertion and reason are false.

151. Human beings are :-

- 1) oviparous and asexually reproducing organisms
 2) oviparous and sexually reproducing organisms
 3) viviparous and asexually reproducing organisms
 4) viviparous and sexually reproducing organisms

152. If both ovaries are removed from human then level of which hormone is decreased in blood ?

- 1) Oxytocin
 2) Prolactin
 3) Estrogen
 4) Gonadotrophic releasing factor

153. **Assertion :** *Australopithecus* hunted with stone weapons but essentially ate fruit.

Reason : *Homo erectus* probably did not eat meat.

- 1) If both assertion and reason are true and the reason is the correct explanation of the assertion.
 2) If both assertion and reason are true but reason is not the correct explanation of the assertion.
 3) If assertion is true but reason is false.
 4) If both assertion and reason are false.

154. What was the most significant trend in the evolution of modern man (*Homo sapiens*) from his ancestors ?

- 1) Shortening of jaws
 2) Binocular vision
 3) Increasing cranial capacity
 4) Upright posture.

155. Given below are four methods (A-D) and their modes of action (a-d) in achieving contraception. Select their correct matching from the four options that follow

| Method | Mode of Action |
|--------------|-------------------------------------|
| A. The pill | (a) Prevents sperms reaching cervix |
| B. Condom | (b) Prevents implantation |
| C. Vasectomy | (c) Prevents ovulation |
| D. Copper T | (d) Semen contains no sperms |

- 1) A - (c), B - (d), C - (a), D - (b)
 2) A - (b), B - (c), C - (a), D - (d)
 3) A - (c), B - (a), C - (d), D - (b)
 4) A - (d), B - (a), C - (b), D - (c)

156. Following is the diagrammatic representation of the operation of natural selection of different traits. Which of the following options correctly identifies all the three graphs A, B and C ?

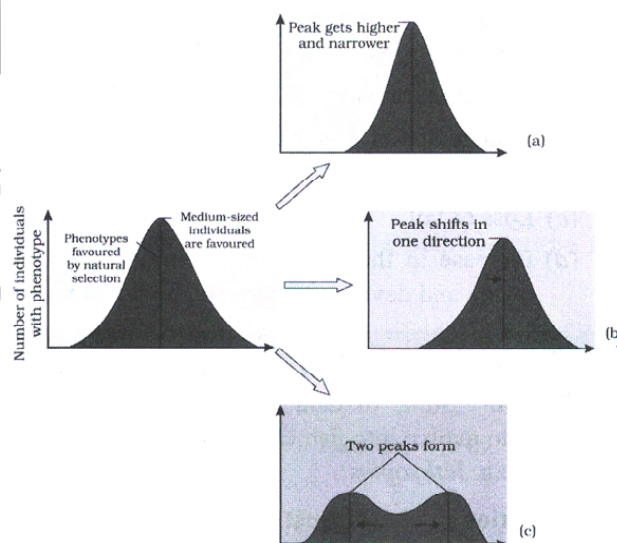

| | A | B | C |
|----|-------------|-------------|-------------|
| 1) | Directional | Stabilizing | Disruptive |
| 2) | Stabilizing | Directional | Disruptive |
| 3) | Disruptive | Stabilizing | Directional |
| 4) | Directional | Disruptive | Stabilizing |

157. Fish with stout and strong fins could move on land and go back to water. This was about
- 1) 350 mya
 - 2) 320 mya
 - 3) 500 mya
 - 4) 200 mya

158. Fill in the blanks according to the convergent evolution.

Placental mammals **Australian mammals**

Anterater a.....

.....b..... Spotted caucus

Flying squirrel c.....

.....d..... Tasmanian tiger cat

- 1) c—flying phalanger, b—lemur, d—bobcat, a—Numbat
- 2) b—flying phalanger, a—lemur, c—bobcat, d—Numbat
- 3) c—flying phalanger, a—lemur, d—bobcat, b—Numbat
- 4) d—flying phalanger, b—lemur, c—bobcat, a—Numbat

159. Example of homologous structures is/are

- 1) Optic lobes of brain
- 2) Heart of vertebrates
- 3) Cerebrum of brain
- 4) All of the above

160. The given diagram represents Miller's experiment. Choose the correct combination of labelling for A, B, C, D and E.

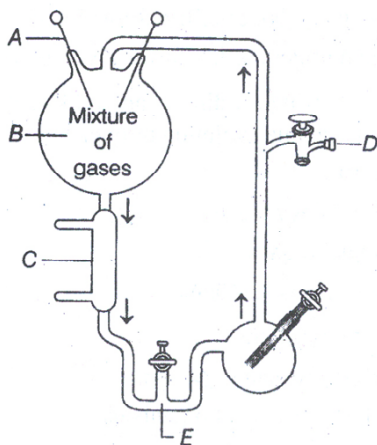

- 1) A-Electrodes, B-NH₃ + H₂ + H₂O + CH₄, C-Cold water, D-Vacuum, E-U-trap
- 2) A-Electrodes, B-NH₄ + H₂ + CO₂ + CH₃, C-Hot water, D-Vacuum, E-U-trap
- 3) A-Electrodes, B-NH₃ + H₂O, C-Steam, D-U-trap, E-Vacuum
- 4) A-Electrodes, B-NH₃ + H₂ + H₂O + CH₄, C-Steam, D-Vacuum, E-U-trap

161. What happened to NH₃ present in the primary atmosphere during its conversion to the secondary atmosphere ?

- 1) It got oxidised to N₂ and water
- 2) It was absorbed by photoautotrophs
- 3) Most of it got oxidised to nitrogen oxides
- 4) Its concentration was decreased due to O₂ formation

162. Life thus cannot originate from inorganic materials now because of

- 1) Low atmospheric temperature
- 2) High degree of pollution
- 3) High atmospheric oxygen.
- 4) Absence of raw materials

163. Choose the correct sequence during formation of chemicals on early earth

- 1) Ammonia, Water, Nucleic acid, Protein
- 2) Ammonia, Proteins, Carbohydrates, Nucleic acid
- 3) Ammonia, Nucleic acid, Proteins, Carbohydrates
- 4) Proteins, Carbohydrate, Water, Nucleic acid

164. The definition of biotechnology given by EFB encompasses

- 1) traditional biotechnology
- 2) modern molecular biotechnology
- 3) DNA fingerprinting
- 4) Both (1) and (2)

165. The different basic steps of genetically modifying an organism are given below randomly.

- I. Identification of DNA with desirable genes.
- II. Transfer of the DNA to its progeny.
- III. Maintenance of introduced DNA in the host.
- IV. Introduction of identified DNA into the host.

Which of the following represents the correct sequence of steps ?

- 1) I, II, III and IV
- 2) I, IV, III and II
- 3) III, IV, II and I
- 4) I, III, IV and II

166. Saheli, A female antifertility pill is used:-

- 1) Daily
- 2) Weekly
- 3) Quarterly
- 4) Monthly

167. Palindrome sequences

- 1) read opposite on two strands
- 2) read specific sequence in opposite direction
- 3) read same on two strands when orientation of reading is same
- 4) read opposite on two strands when orientation of reading is same

168. Purpose of tubectomy is to prevent:-

- 1) Egg formation
- 2) Embryonic development
- 3) Tertilization
- 4) Coitus

169. An enzyme catalysing the removal of nucleotides from ends of DNA is
- 1) DNA ligase
 - 2) endonuclease
 - 3) exonuclease
 - 4) protease
170. Identify A, B, C and D in the given diagram of E. coli cloning vector pBR322.

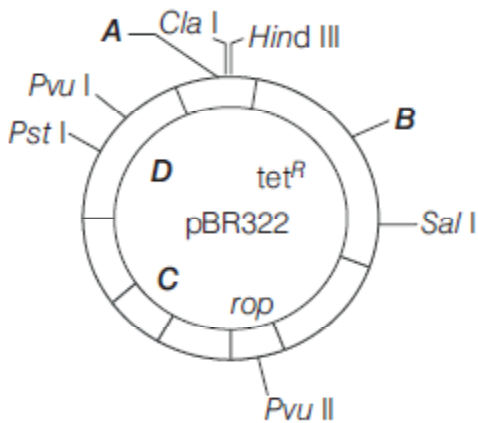

- 1) A–Eco RI, B–Bam HI, C–ori, D–amp^R
 - 2) A–amp^R, B–ori, C–Bam HI, D–Eco RI
 - 3) A–ori, B–Bam HI, C–Eco RI, D–amp^R
 - 4) A–Bam HI, B–Eco RI, C–amp^R, D–ori
171. Consumption of which one of the following foods can prevent the kind of blindness associated with vitamin-A deficiency ?
- 1) *Flavr Savr* tomato
 - 2) Canolla
 - 3) Golden rice
 - 4) *Bt* brinjal
172. Which of the following is a hormone releasing Intra Uterine Device (IUD) ?
- 1) Multiload 375
 - 2) LNG - 20
 - 3) Cervical cap
 - 4) Vault
173. *cry* IIAb and *cry* IAb produce toxins that control
- 1) cotton bollworms and corn borer, respectively
 - 2) corn borer and cotton bollworms, respectively
 - 3) tobacco budworms and nematodes, respectively
 - 4) nematodes and tobacco budworms, respectively

174. RNAi stands for
- 1) RNA interference
 - 2) RNA interferon
 - 3) RNA inactivation
 - 4) RNA initiation
175. Artificial insemination means :
- 1) introduction of sperms of a healthy donor y directly into the ovary
 - 2) ytransfer of sperms of a healthy donor to a test tube containing ova
 - 3) transfer of sperms of husband to a test tube containing ova
 - 4) Tartificial introduction of sperms of a healthy donor into the vagina
176. For the first time, gene therapy was tried on a 4 year old girl in 1990 to treat which of the following enzyme deficiency ?
- 1) Cytosine Deaminase (CDA)
 - 2) Adenosine Deaminase (ADA)
 - 3) Tyrosine oxidase
 - 4) Glutamate trihydrogenase
177. Which of the following techniques is based on the principle of antigen-antibody interaction ?
- 1) PCR
 - 2) ELISA
 - 3) Recombinant DNA technology
 - 4) Gene therapy
178. An IUCD is:-
- 1) Vasectomy
 - 2) Copper
 - 3) Condom
 - 4) All above
179. A contraceptive pill contains:-
- 1) Progesterone and estrogen
 - 2) Spermicidal salts
 - 3) Chemicals that cause automatic abortion
 - 4) Chemicals that prevent fertilization of ovum
180. Common duct formed by union of vas deferens and duct from seminal vesicle is :-
- 1) urethra
 - 2) rete testis
 - 3) ejaculatory duct
 - 4) epididymis

Space For Rough Work

ALPHA-CONCEPT SERIES



प्रा. चिराग सरांचे
Alpha 360° Academy



Academic Director
Prof. Chirag Senma



Lectures start from 18 May at 5:00 PM.



| Date | CHEMISTRY | PHYSICS | BIOLOGY |
|--------|----------------------|---------------------|--|
| 18 May | Organic: Part - 01 | Concept Series - 01 | Zoology |
| 19 May | Organic: Part - 02 | Concept Series - 02 | |
| 20 May | Inorganic: Part - 01 | Concept Series - 03 | Zoology |
| 21 May | Inorganic: Part - 02 | Concept Series - 04 | |
| 22 May | Physical: Part - 01 | Concept Series - 05 | Zoology |
| 23 May | Physical: Part - 02 | Concept Series - 06 | |
| 25 May | | | Genetics, MBI, Biotech I & II, Cell, CCD, Biomolecules |
| 26 May | | | Botany |

📍 Signal Camp, Udyog Bhavan, **Latur**

📞 **7767007744 | 7767007733**

🌐 www.alpha360degree.com

📍 Indraprastha Society, Opp. Netaji Subhash
Mangal Karyalaya, Hadapsar, **Pune**

📞 **7378882123**